

Part No./型号: RGB-Controller-101

● **Instructions:**

Thank you for using RGB-Controller-101 of our company. Before installation, please read this manual carefully to ensure fully understand and proper use in order to avoid unnecessary damages to the controller.

Before using, please check to confirm whether there is any damage caused during the transport process, if there is, please notify your supplier and do not use the product.

● **After-sale services:**

Warranty of this product is one year, in this period we guarantee repairing or replacement service with no charge if it is normally used according to the instruction.

If the customer does not follow the instructions and following provisions in this manual, which results in product damage, the supplier is not responsible for any problems arising and defects, even in the warranty period, maintenance costs borne by the customer.

1. Damage caused by misuse, such as not in accordance with the instructions.
2. Damages caused by unauthorized removal, repair, modify of the circuit; incorrect connection and replacement of the chips.
3. Damage caused by transportation, shock, falling after purchase.
4. Damage caused by earthquake, fire, flood, lightning and abnormal voltage.
5. Damage caused by negligence or improper maintenance, such as storage at high temperature and humid environment, vicinity of hazardous chemical substances.
6. Replacement of products.

● **Instructions for safety:**

Making sure you use the product perfectly and safely, please observe the instructions and warning on this manual.

Attention! Operate cautiously and read these instructions carefully.

1. For installation, try to avoid the minefields, strong magnetic field and high-pressure area.
2. Ensure that the wire is connected correctly and firmly in order to avoid short-circuit damage to parts and posing a fire hazard.
3. Please install controller in a well-ventilated place to ensure that the ambient temperature is moderate.
4. Before using this product, please check the DC power and voltage meet the product technical requirements; positive and negative polarity is defined consistent to the product.
5. Prohibit live wiring, check to confirm wiring is correct, if no short-circuit, then power!
6. If any problems do not make unauthorized repairs. Any doubts please contact your local supplier.

This manual applies only to this product of our company, subject to changes without notice.

● **Introduction**

This RGB series controller is a smart RGB three colors light controller dedicated to long-illumination LED light, using the most advanced PWM (Pulse Width Modulation) digital control technology, the controller can be operated through IR wireless remote controller. The installation of LED controller can apply to commercial or home lighting on different occasion with different environment, extend the LED life span, and save energy; LED and RGB lights can use this controller to decolorize.

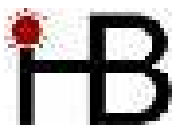

Part No./型号: RGB-Controller-101

1. Technology specifications

Type	RGB-Controller-101
Input power	DC12V
Output signal	RGB three channels signal
Max load current	6A
Output power	72W(12V)
Controller dimension	L57×W35× H22.5 (mm)
Remote dimension	L85×W52×7(mm)
Packaging dimension	L91.7×W66×H52(mm)
Gross weight	73g

2. Functions

- (1).RGB full colors LED strip controller.
- (2).Control way: Wireless control, it is available in 100-meter (No barriers).
- (3).Display:16 static, 3 colors jump change, 7 colors jump change, 3 colors gradual change, 7 colors gradual change.
- (4).Speed of dynamic can adjust. Brightness of static can adjust.
- (5).Having memory when power fails.
- (6).Function of both controller and dimmer.
- (7).Standby function.
- (8).Colorized control panel
- (9).Black and white shells are optional.
- (10).RGB three channels signal (A total of positive and negative).

3. Structure

(1).View of major controller: (chart 1)

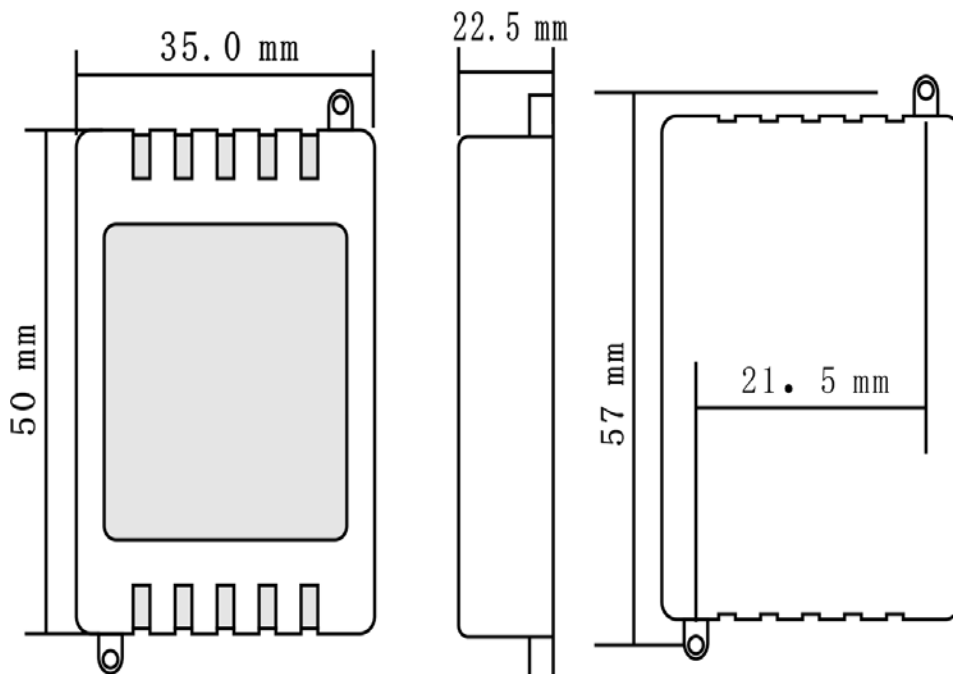

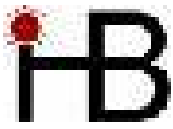

Part No./型号: RGB-Controller-101

(2). View of remote controller (chart 2).

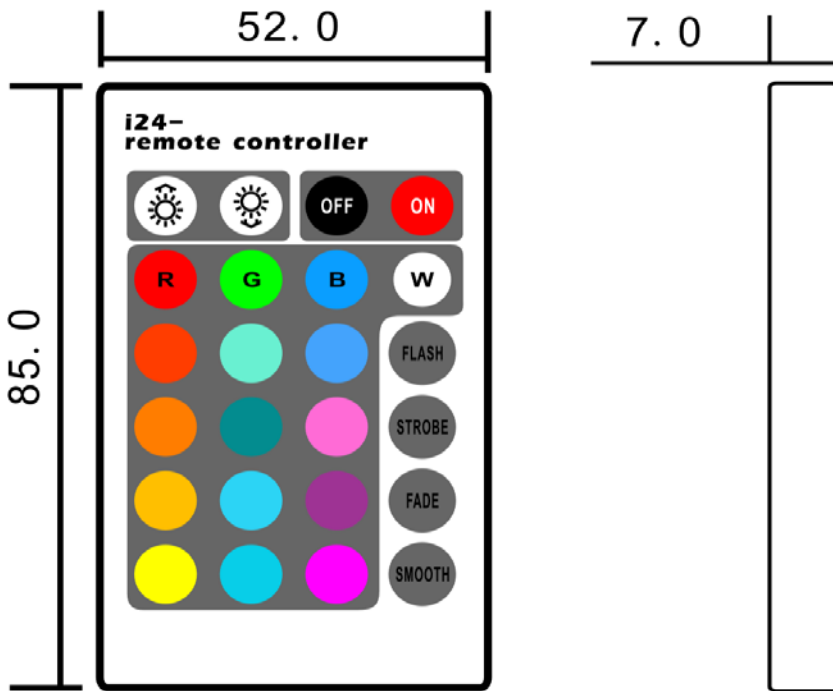





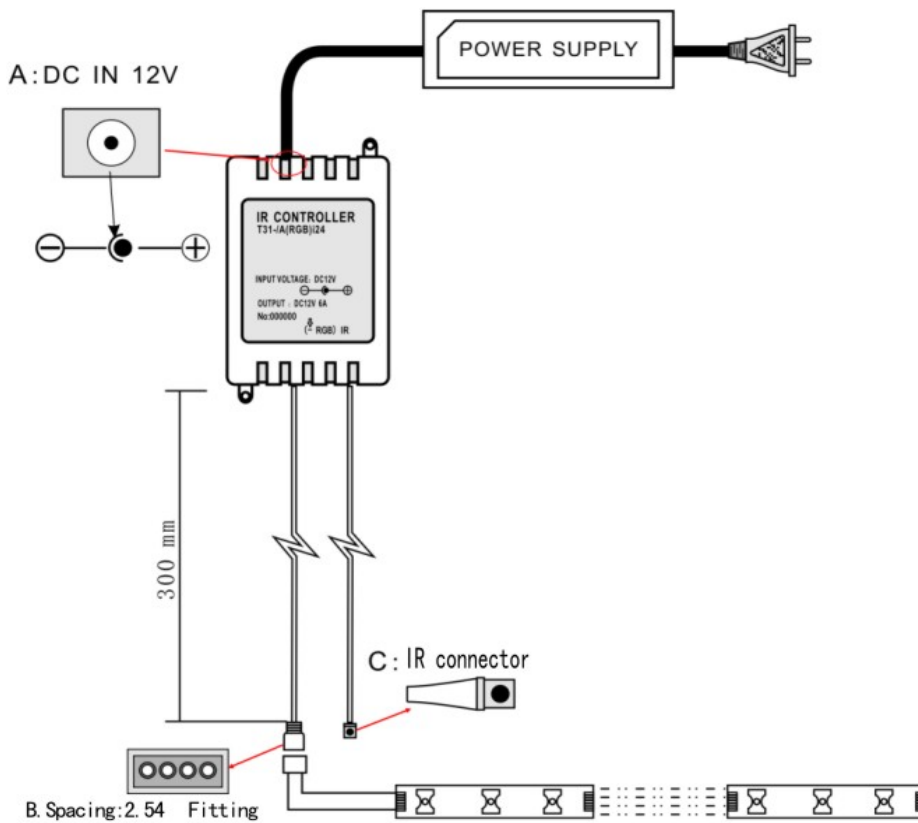

















4. Connection diagram of controller

(1).Connection diagram to low power LED: (chart 3)



Part No./型号: RGB-Controller-101

(2).Descriptions for panel and remote controller keys.

Symbol	Name	Function
	OFF/ON	On/off: turn on or off the LED controller
	BRT+ / BRT-	 :increase/decrease brightness, totally 16-level brightness, press and hold can change brightness continuously
 R static red	 G Static green	 Static blue
 static orange	 Static light green	 Static deep blue
 static deep yellow	 Static cyan	 Static pink
 static yellow	 Static light blue	 Static purple
 Static light yellow	 Static sky blue	 Static magenta
		 Static white
		 7 colors jump change
		 White gradual change
		 7 colors gradual change
		 Three primary colors jump change

5. Failure analysis and solutions

Failure	Analysis	Solutions
No light	<ol style="list-style-type: none"> 1. No power. 2. Reversed the polarity. 3. Wrong connection or poor contact. 4. LED light has been bad. 	<ol style="list-style-type: none"> 1. Check the power 2. Make sure the polarity is right. 3. Re-check the wire connection.
Brightness of LED is not consistent	<ol style="list-style-type: none"> 1. Input wire is too long to cause wire loss. 2. Diameter of wire is too thin to cause wire loss. 3. Power overload. 4. Controller overload. 	<ol style="list-style-type: none"> 1. Shorten wire or use loop circuit. 2. Calculate the current, and then replace thick wire. 3. Replace larger power. 4. Add a power amplifier

Tips: The effective power is generally only 80% of the marked power, so it is recommended in selecting the power supply, the user choose a slightly larger one than the LED load power, at least for more than 20%!

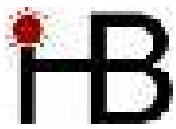

Part No./型号: RGB-Controller-101

Appendix: dynamic modes' description (list 3) .



Mode	Description
FLASH	Three colors jump change: red→green→blue
STROBE	Seven colors jump change: red→green→blue→yellow→cyan→purple→white
FADE	Three colors gradual change: red→green→blue
SMOOTH	Seven colors gradual change: red→green→blue→yellow→cyan→purple→white

6. Packaging

(1).Packaging details (chart 4).



(2).Packaging list (list 4).

Symbol	Name	Picture	External dimension(mm)	QTY	Unit
A	B/A(RGB) Controller		57*35*22.5(mm)	1	PCS
B	IR(controller)		85*52*7.0(mm)	1	PCS
C	Manual	31E0RGB	A6 sheet	1	PCS

(3). Carton packaging

Small Box Packing: 40PCS/carton

